

KS XL- Verarbeitungsrichtlinie.

Rationell mauern mit großformatigen Kalksandsteinen.

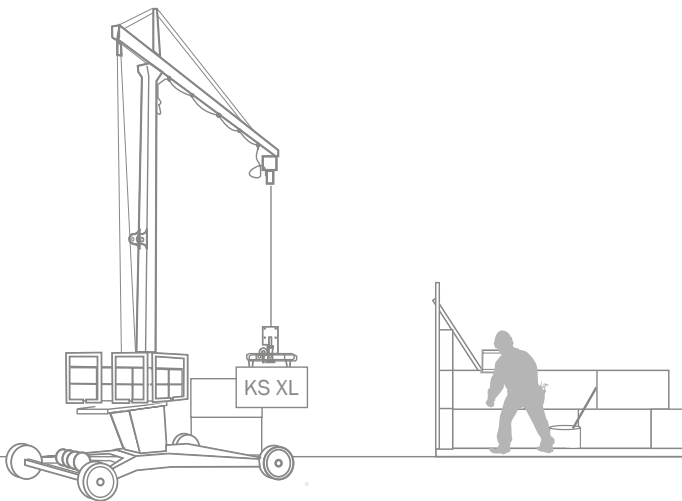

→ ks-original.de

Kalksandstein
KS*
DAS ORIGINAL

KALKSANDSTEIN
KS XL-Verarbeitungsrichtlinie

Herausgeber: Bundesverband Kalksandsteinindustrie e.V.
Entenfangweg 15, 30419 Hannover, Telefon 0511/2 79 54-0
www.kalksandstein.de, www.facebook.com/kalksandstein

4. Auflage 2020

Stand: Mai 2020

BV-924-20/05

Redaktion:

Dipl.-Ing. A. Germann, Stuttgart

Dipl.-Ing. W. Grethe, Hannover

Dipl.-Ing. C. Runge, Ahlhorn

Gesamtproduktion und

© Verlag Bau+Technik GmbH, Erkrath

Alle Angaben erfolgen nach bestem Wissen und Gewissen, jedoch ohne Gewähr.
Nachdruck, auch auszugsweise, nur mit schriftlicher Genehmigung.

Inhalt

1. Großformatige Steine = KS XL	4
2. Werkzeuge und Hilfsmittel.....	7
3. Allgemeine Hinweise zur Lagerung und Verarbeitung von KS XL.....	11
4. Arbeitsvorbereitung.....	13
5. Anlegen der Kimmschicht.....	16
6. KS XL-Dünnbettmörtel anmischen und aufziehen.....	18
7. Aufgehendes Mauerwerk.....	22
8. Überbindemaß.....	24
9. Mauern bei sehr hohen oder sehr niedrigen Temperaturen.....	25
10. Stumpfstoßtechnik bei KS XL	26
11. Schutz vor Beschädigungen.....	29

1. Großformatige Steine = KS XL

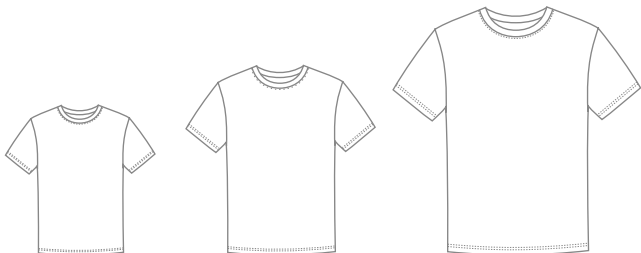

KS

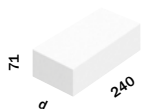

KS -R-Planstein

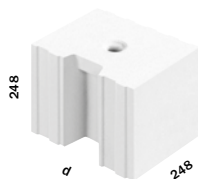

KS XL-RE

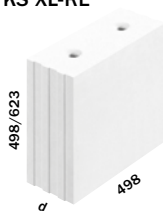

KS XL-PE = KS XL-Planelemente
KS XL-RE = KS XL-Rasterelemente

KS XL-PE

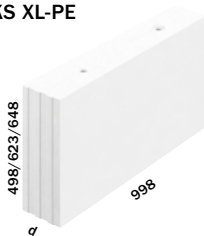

KS XL-PE

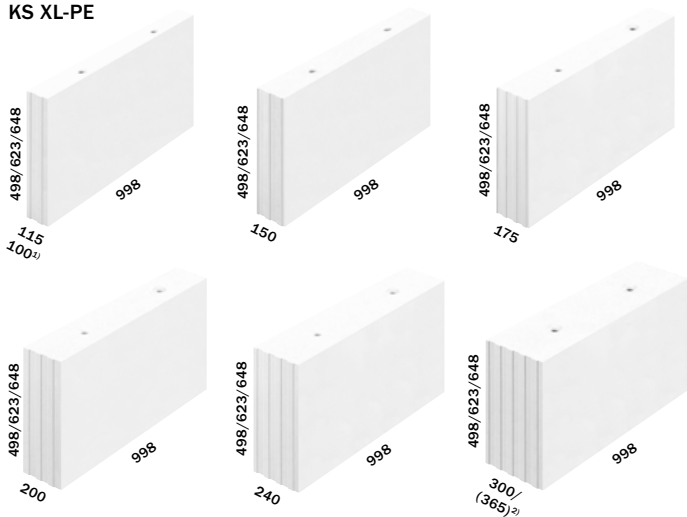

¹⁾ Nur für nicht tragende Wände

²⁾ Die regionalen Lieferprogramme sind zu beachten.

Bausatz mit Verlegeplan

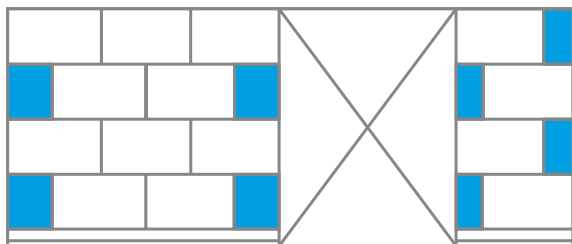

 Passelemente, vorkonfektioniert

KS XL-RE

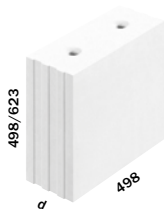

$d = 100^{21}/115/150/175/200/240/300/(365)^{22}$

¹⁾ Nur für nicht tragende Wände

²⁾ Die regionalen Lieferprogramme sind zu beachten.

12,5er-Raster

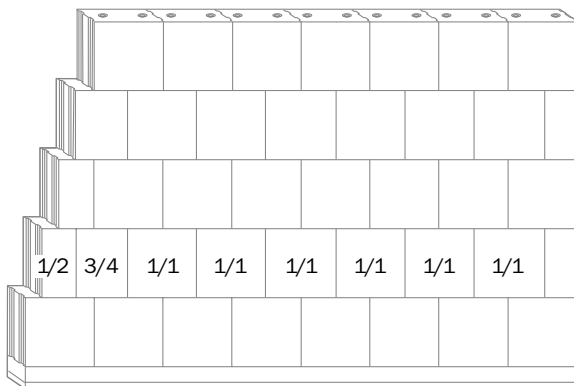

2. Werkzeuge und Hilfsmittel

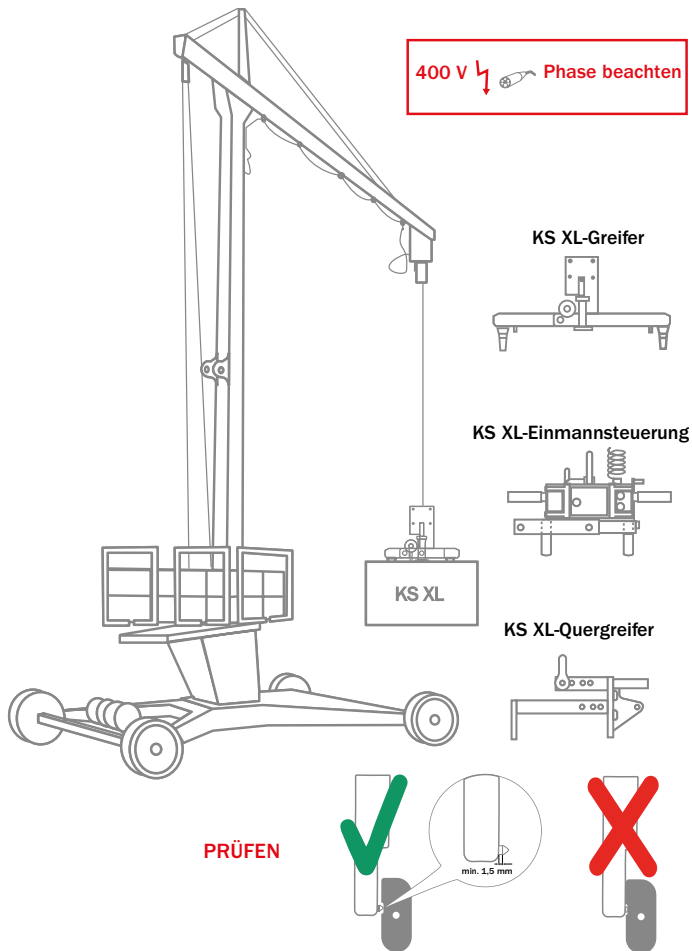

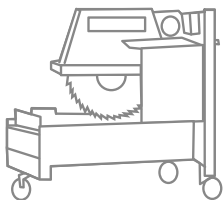

oder

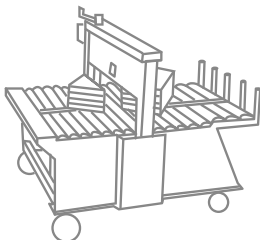

400 V



Phase beachten

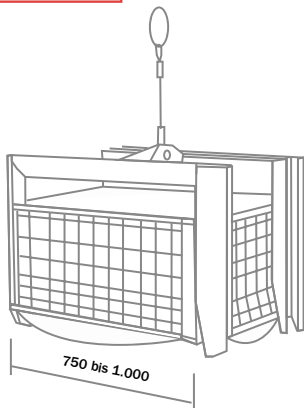
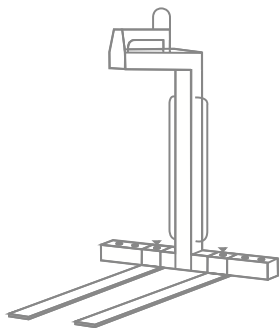

KS XL-PE

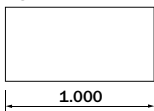

KS XL-RE

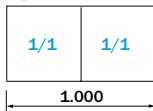

KS XL-RE

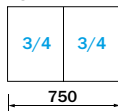

KS XL-RE

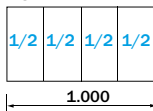

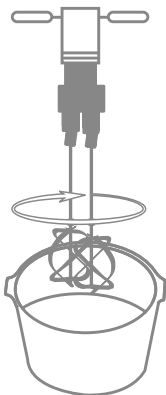
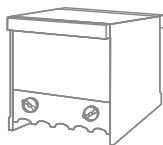
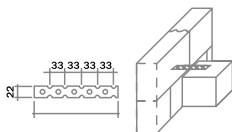

Hochbau-Laser

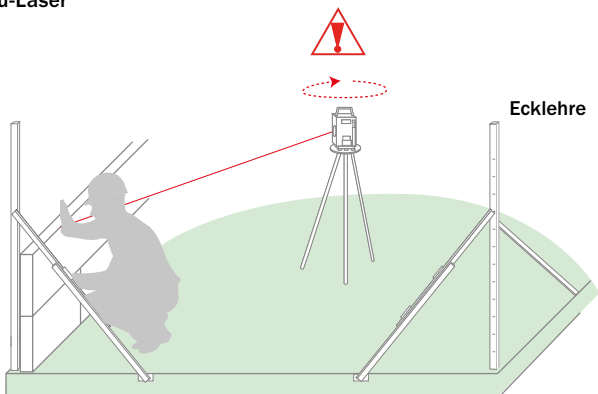

oder

Schlauchwaage

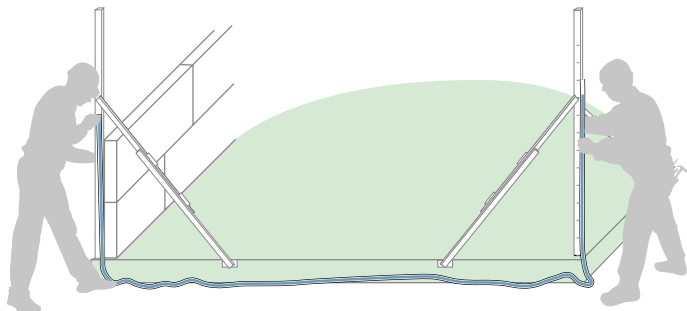

3. Allgemeine Hinweise zur Lagerung und Verarbeitung von KS XL

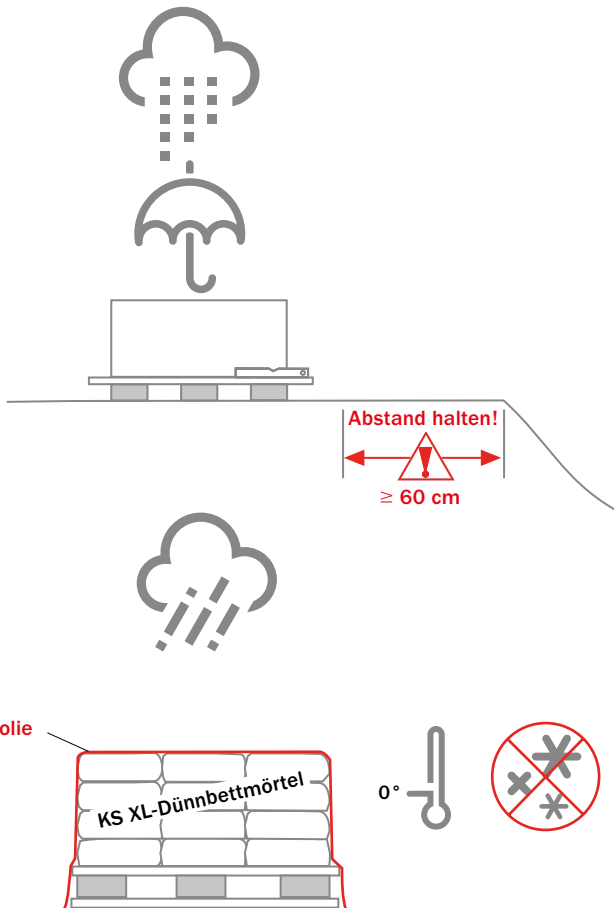

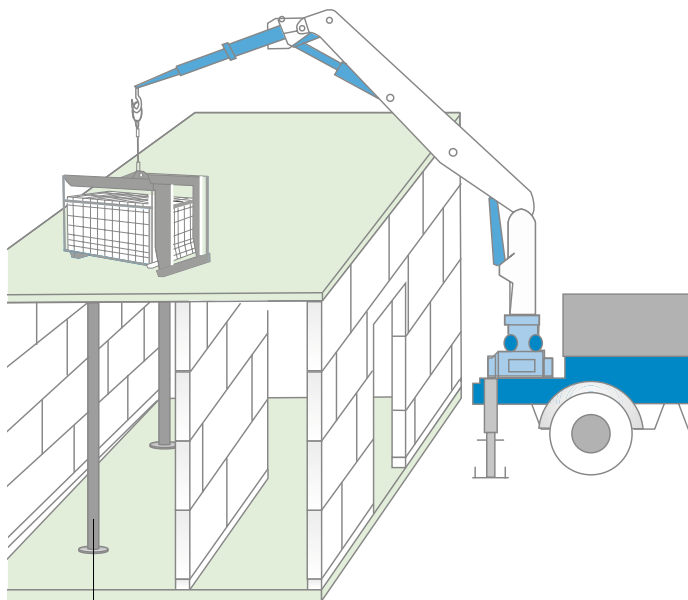

Montagestützen

4. Arbeitsvorbereitung

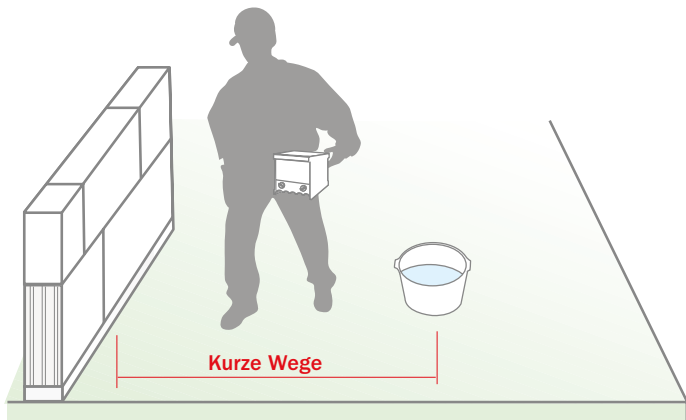
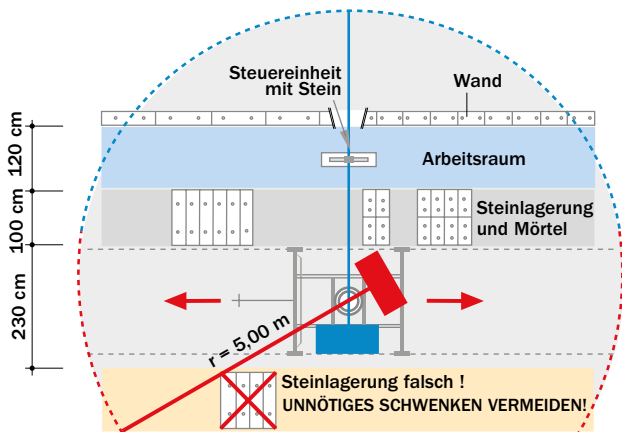

Wandweise bereitstellen

KS XL-PE

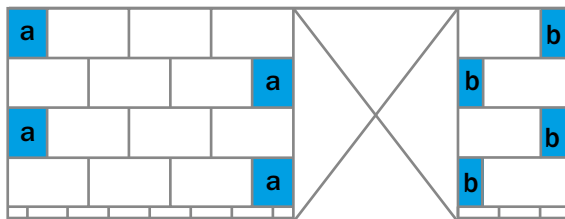

Geschossweise bereitstellen

KS XL-RE

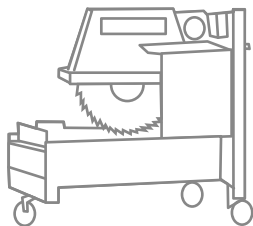
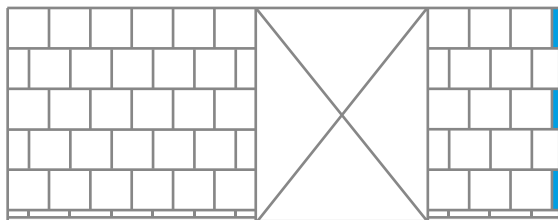

oder

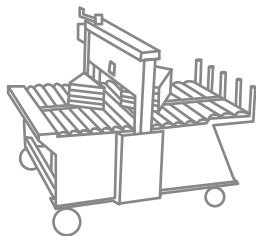

5. Anlegen der Kimmschicht

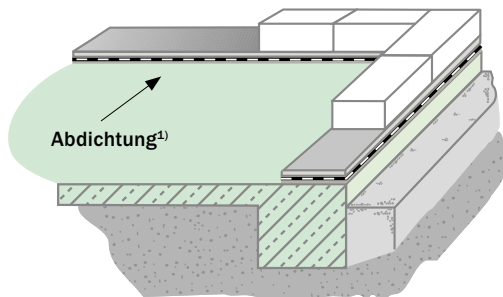

¹⁾ Als Querschnittsabdichtung bei Kalksandstein können mineralische Dichtungsschlämmen oder in Mörtel eingebettete **besandete** Bitumendachbahnen (z.B. R 500) verwendet werden.

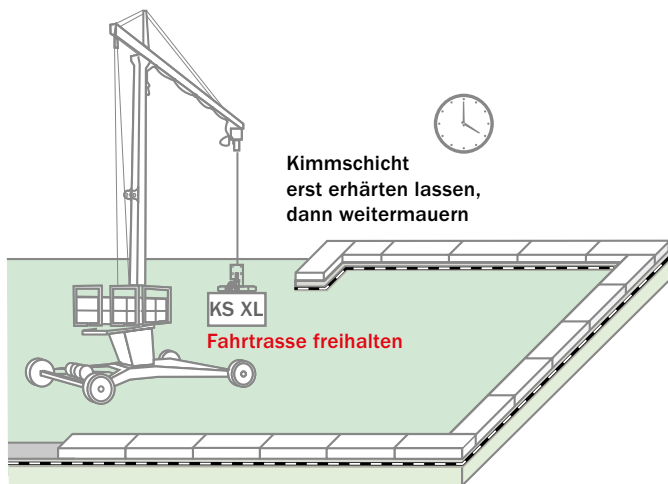

Kimmreihe

Höhenausgleichsteine

M10

(NM III) $\leq 3 \text{ cm}$

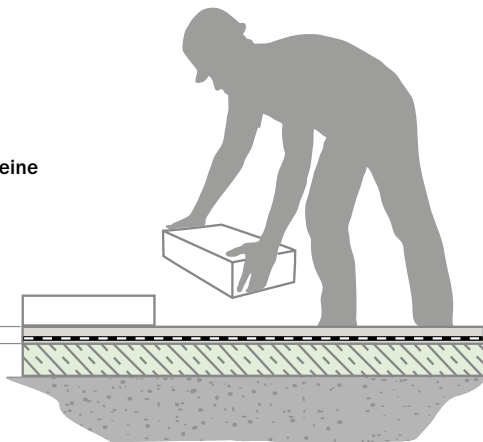

Ausrichten

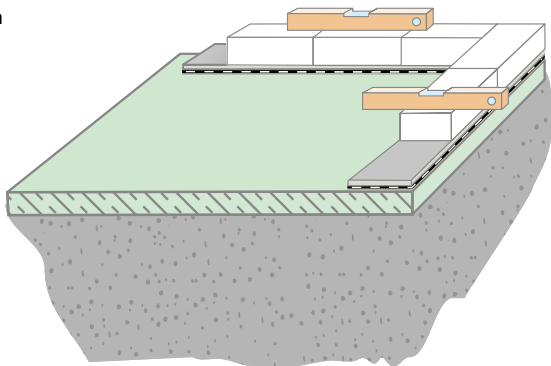

6. KS XL-Dünnbettmörtel anmischen und aufziehen



+



= fix und fertig

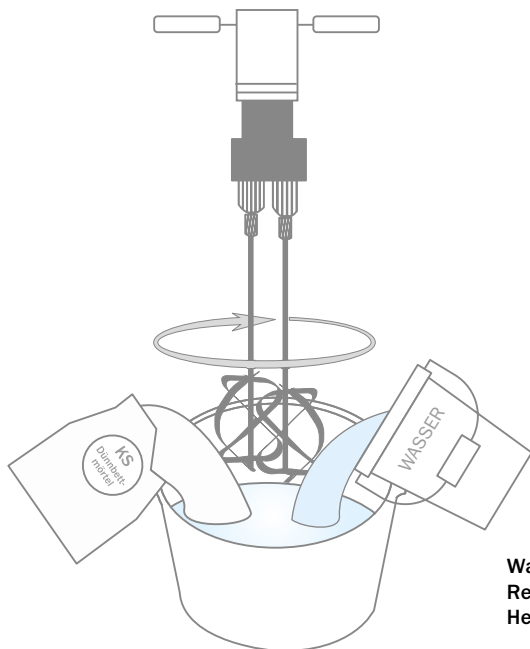

**Wassermenge und
Reifezeit nach
Herstellerangaben!**

Abfegen

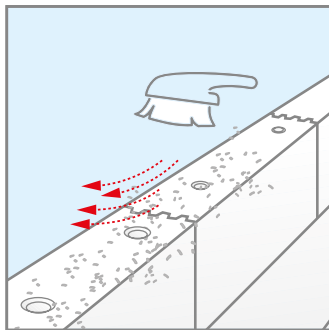

Mörtelauftrag mit Mörtelschlitten

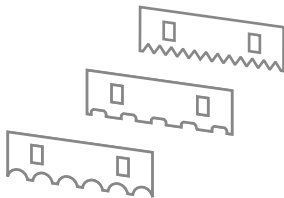
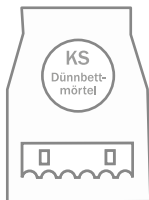
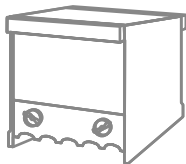
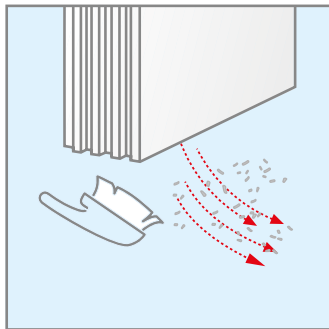
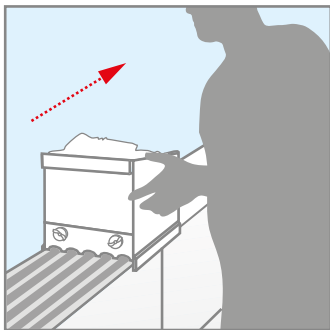

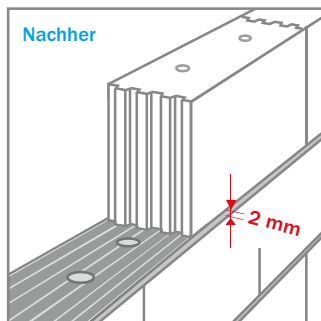
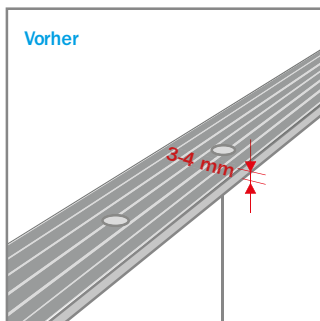

Mörtelauftragsdicke 3 bis 4 mm

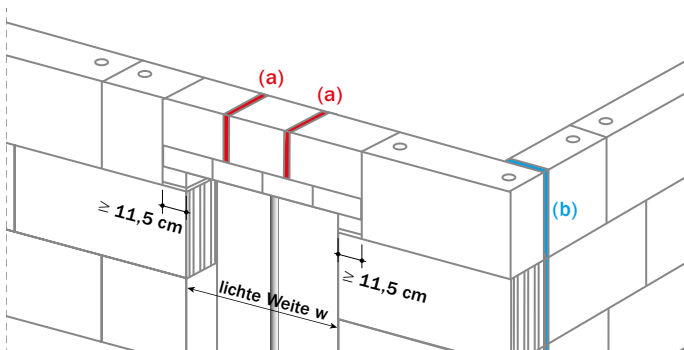

Die **Stoßfugen in der Sturzübermauerung (a)** und die **Stumpfstoßfugen (b)** sind stets mit Dünnbett- oder Normalmauermörtel zu vermörteln!

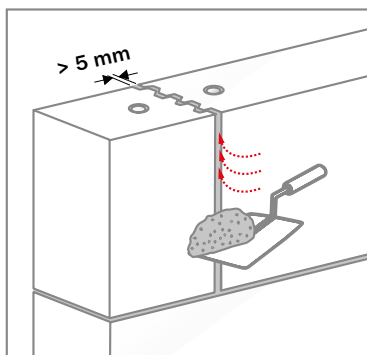
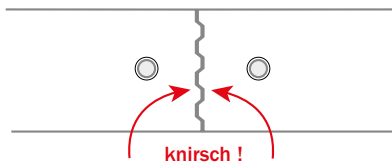

7. Aufgehendes Mauerwerk

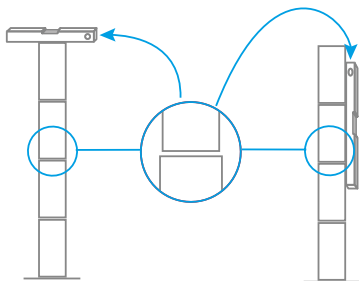
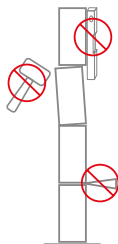
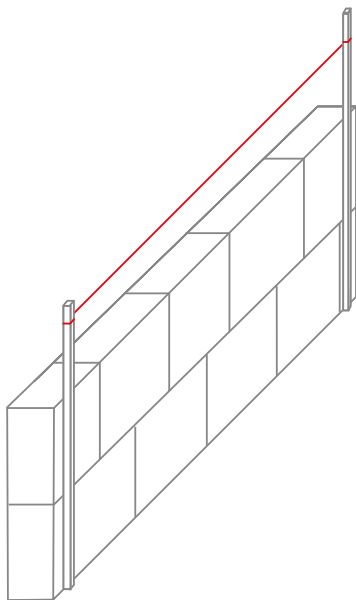

Versetzen der KS XL

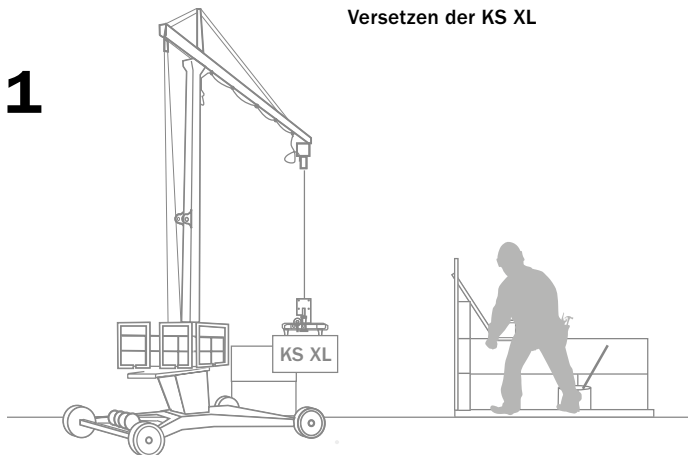
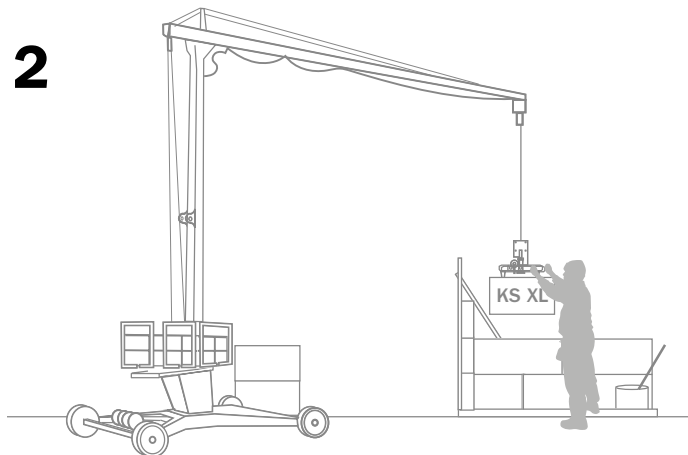
1**2**

8. Überbindemaß

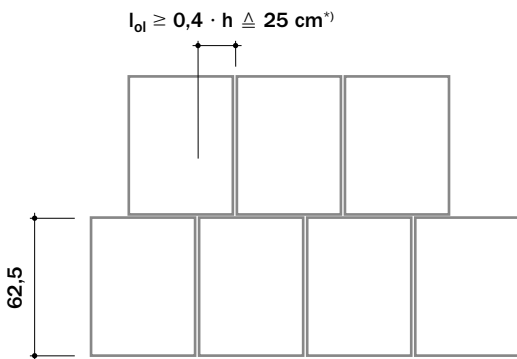
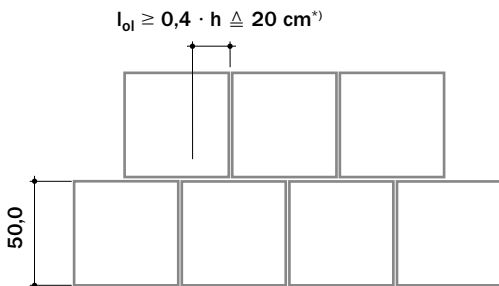

*) Das Überbindemaß l_{ol} darf bei Elementmauerwerk bis auf $0,2 \cdot h$ (mindestens jedoch 12,5 cm) reduziert werden, wenn es in der statischen Berechnung berücksichtigt wurde.

9. Mauern bei sehr hohen oder sehr niedrigen Temperaturen

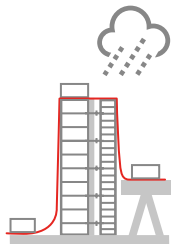

Kein Tausalz
im Rohbau
verwenden!



Frost

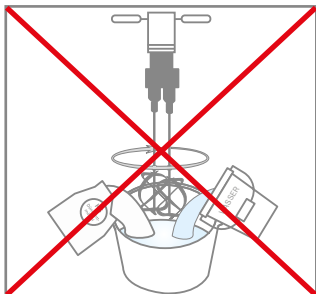
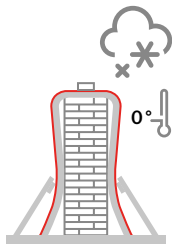

Hitze

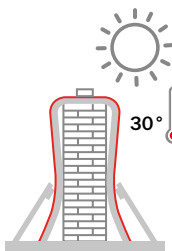

Vornässen

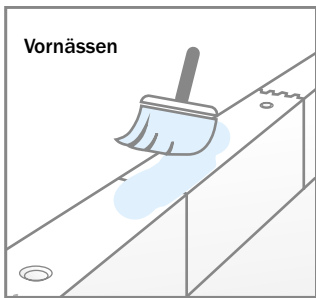

10. Stumpfstoßtechnik bei KS XL

Stumpfstoßfugen sind vollflächig mit Dünnbettmörtel (2 bis 3 mm dick) oder Normalmauermörtel (1 bis 2 cm dick) zu vermörteln.

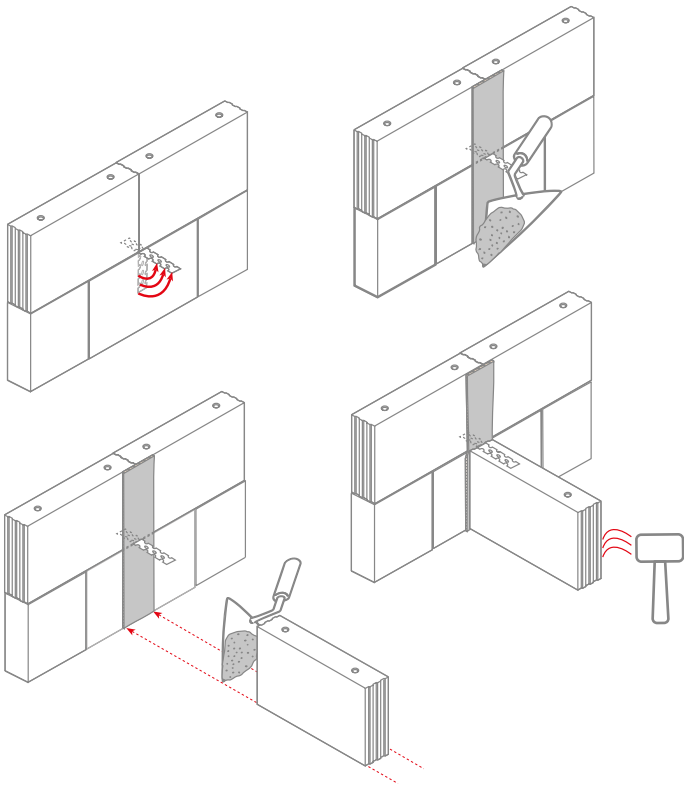

INFO

Außenwanddecken in Kellergeschossen sind grundsätzlich im Verband auszuführen!

Durchbinden einer Wohnungstrennwand

Schallschutzdetail Wohnungstrennwand

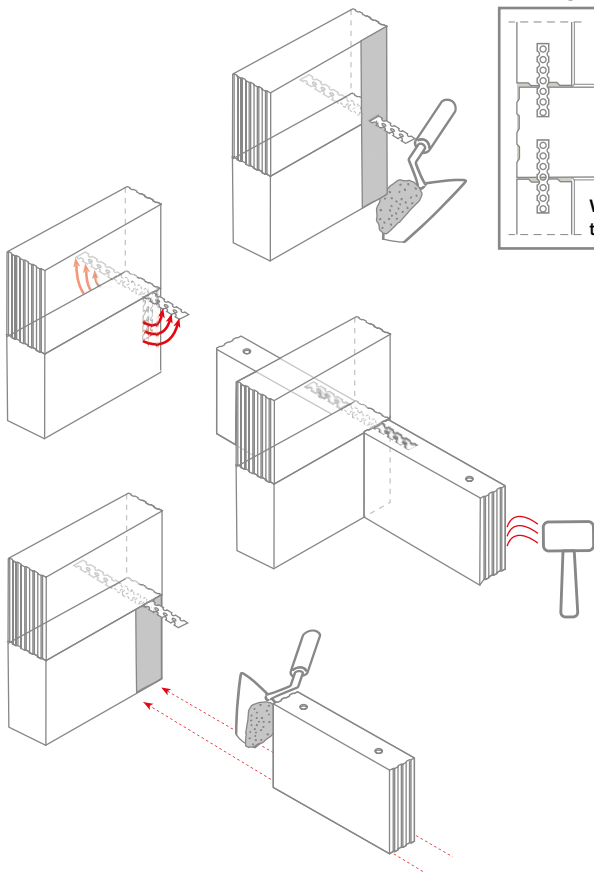
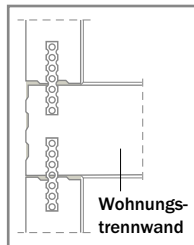

Längenausgleich über die Stoßfugen der Zwischensteine

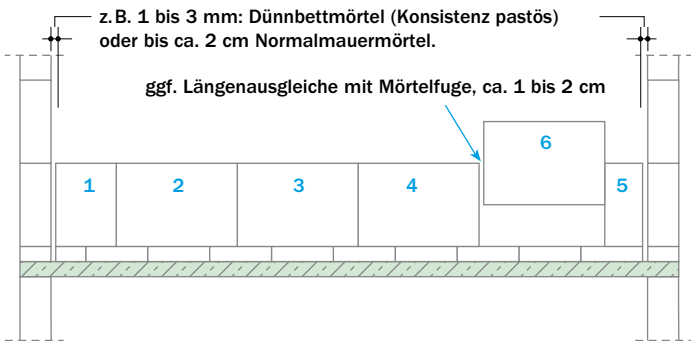

INFO

Außenwanddecken in Kellergeschossen sind grundsätzlich im Verband auszuführen!

11. Schutz vor Beschädigungen

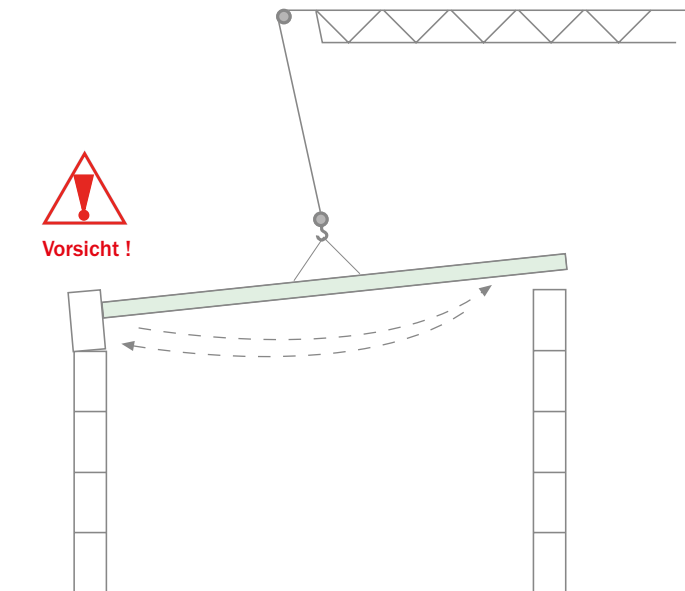

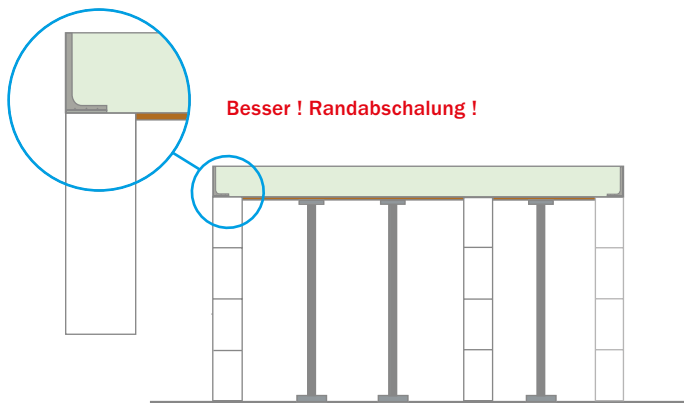
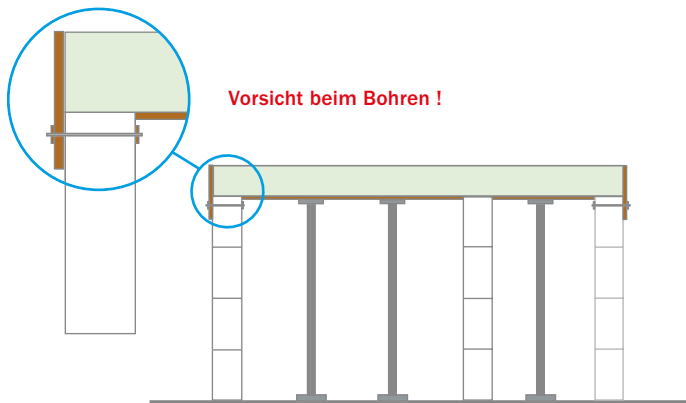

KS* Partner in Ihrer Nähe.

→ ks-original.de/partner ☎ 0800 7002070

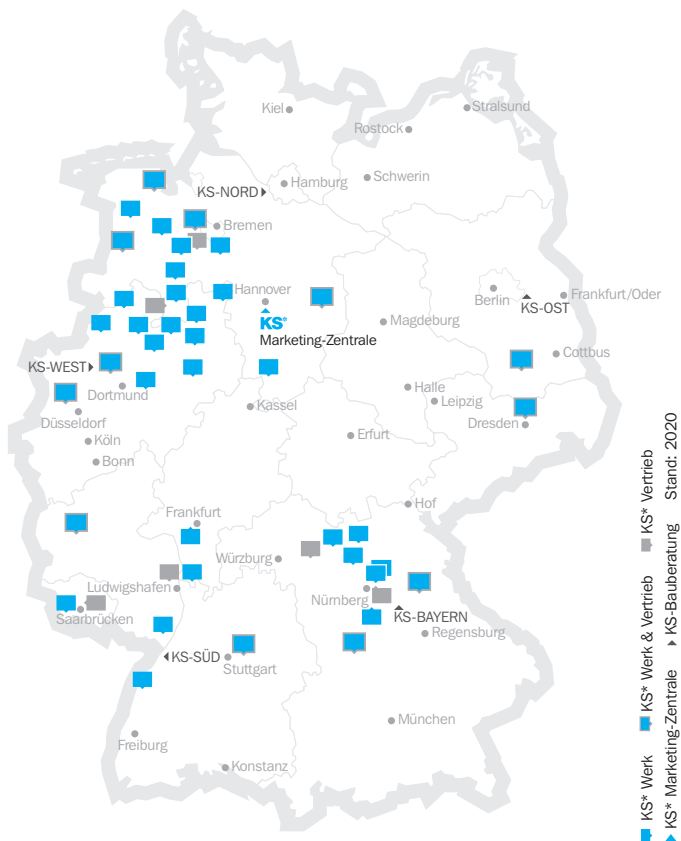

Finden Sie den regionalen KS* Partner in Ihrer Nähe sowie detaillierte Informationen rund um den Wandbaustoff Kalksandstein:

→ ks-original.de

Kalksandstein
KS*

DAS ORIGINAL

KS-ORIGINAL GMBH
Entenfangweg 15
30419 Hannover

Tel.: +49 511 27953-0
Fax: +49 511 27953-31
info@ks-original.de
ks-original.de



Einfach einscannen und
Fachinformationen entdecken.